



Linear Motion Solutions for Clean Energy Applications



Solar Energy

High energy prices continue to fuel growth in the solar energy industry. A key factor in deployment of solar panels is the efficiency of the panels and the amount of energy created from the given surface area of a panel.

Solar panel tracking

Tracking the movement of the sun will boost the efficiency and increase output from a given panel by up to 30%. Accurate, trouble-free positioning of the panels is the challenge. The system must be highly rugged and able to withstand wind and weather. It must function reliably and maintenance-free for many years. Thomson linear actuators and screw jacks offer affordable, custom-fitted solutions to these challenges.

- Solar tracking requires actuation solutions which are stiff and will not back-drive in high wind conditions. All Thomson actuators and screw jacks can be equipped with a holding brake that eliminates back-driving.

Customization

Thomson has a long history of building custom products. A custom tailored solution can be an integrated part of the structure and make assembly quick and easy.

Feedback

Thomson actuators and screw jacks are offered with both analog and digital feedback to allow precise tracking of the sun.

- Accurate tracking often requires some form of feedback. Most Thomson actuators and screw jack models can be equipped with encoders, resolvers or potentiometers to meet either analog or digital feedback requirements.
- All Thomson actuators and screw jacks are available with adjustable end of stroke limit switches to protect the panel from damage due to overtravel in either direction.
- Panels can require up to 2000 lbf. of force to move in windy conditions, which both actuators and screw jacks can deliver with ease.
- Multiple mounting options are available.
- Actuators and screw jacks require little to no maintenance, making them ideal for solar panel applications.

Wind, rain and snow

The elements can put stress on a solar panel. Thomson actuators and screw jacks are built to handle these conditions with little or no service or maintenance at all.

Limit the movement

Both actuators and screw jacks can be supplied with built-in adjustable end of stroke limit switches which makes it easy to set the limits of movement.

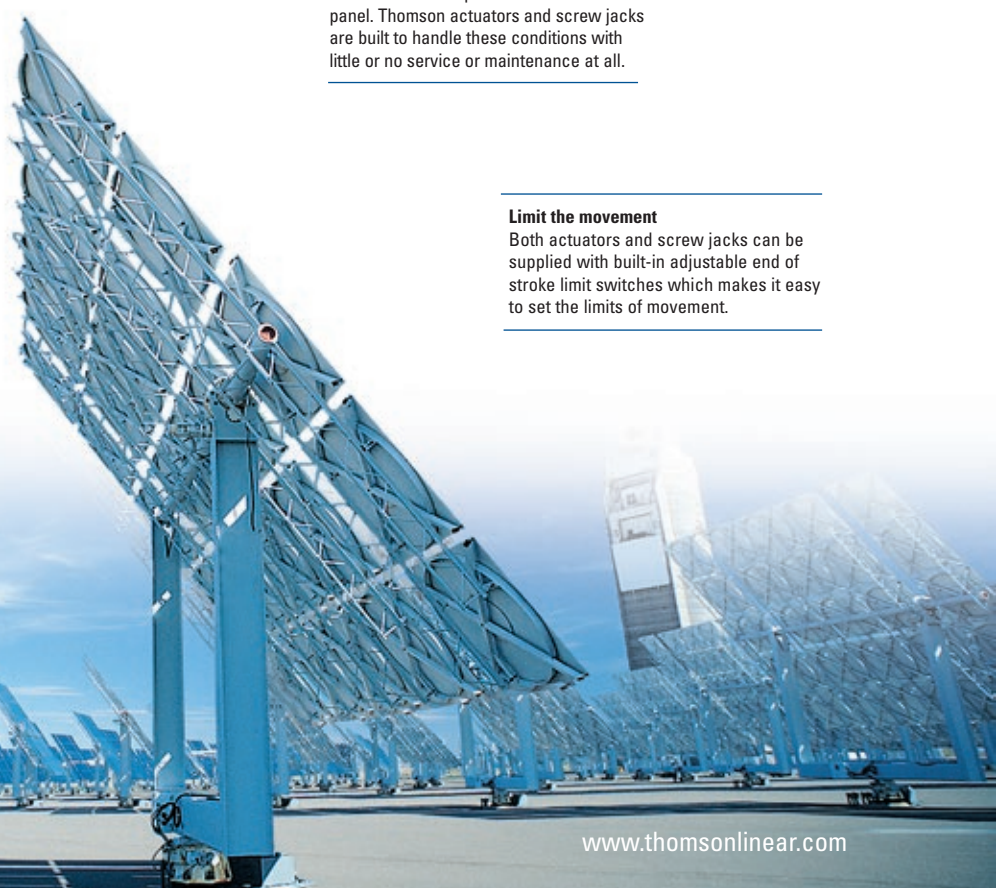

Wind Energy

The best wind conditions are often found in locations that are remote or hard to reach – at sea, in the middle of a large field and on hill-tops. Harsh environments require rugged solutions. Reliability is essential and maintenance needs to be minimized. Millions of Thomson actuators operate reliably for years without maintenance in the harshest environments.

Hood lifting and parking brakes

Wind mills are built with top hatches to allow maintenance of large components in the turbine house. These hatches are often too heavy to operate manually. The turbine itself also needs to have a parking brake so that the rotor stays in position for service or when the wind conditions require the mill to stop. Linear actuators or screw jacks are the ideal solution in both cases.

Hood lift

Heavy service hoods need to be powered to open even if covered by ice making an actuator or screw jack ideal.

Rotor Brake

A rotor braking function can easily be done using an actuator or a screw jack. The brake is used when serviced and when the wind conditions are such that the rotor must be parked.

- Actuators and screw jacks are clean compared to hydraulic alternatives. They do not require pumps, pipes, valves and plumbing. There is no risk of oil leakage or need for maintenance.
- Positioning is easy with end of stroke limit switches readily available.
- Installation and operation is simple.
- Thomson actuators or screw jacks have a variety of mounting options available, allowing flexible configuration.

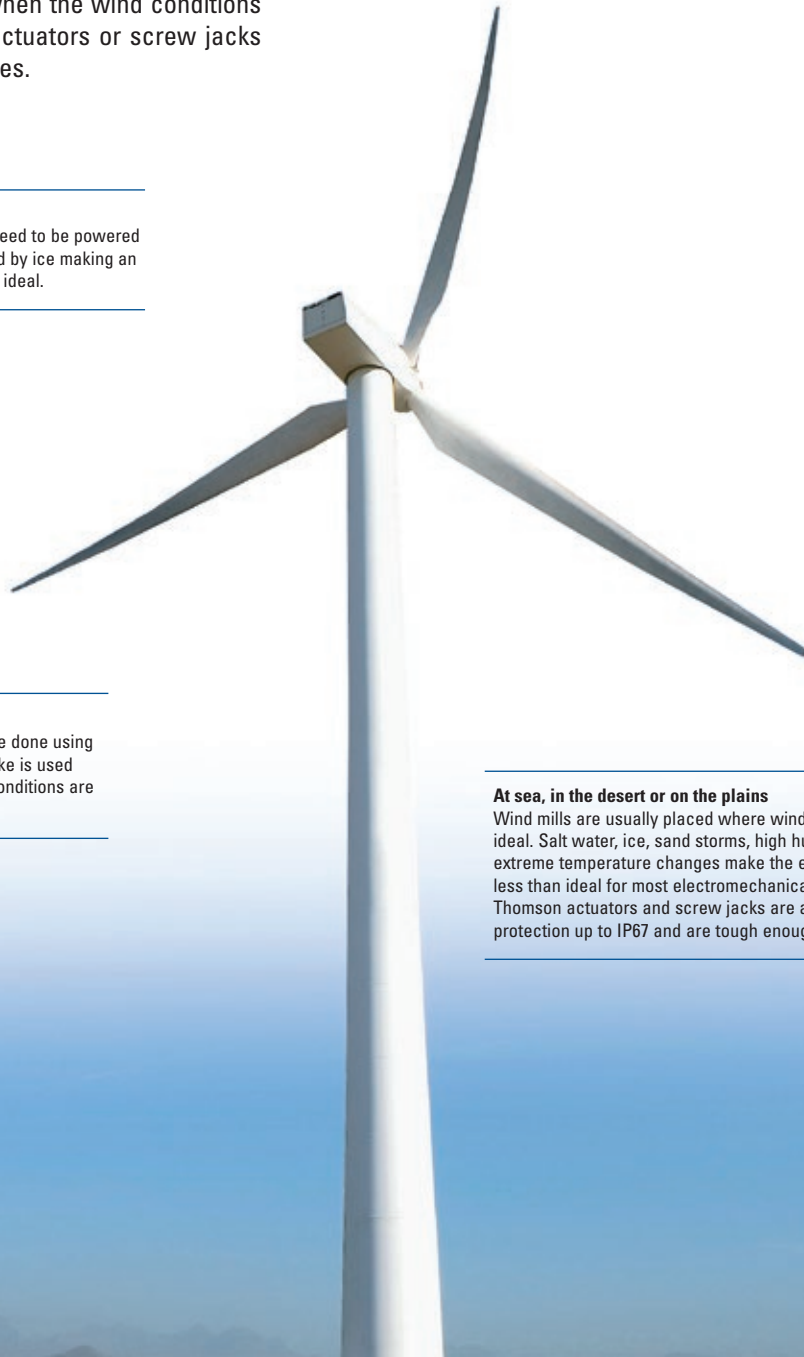

At sea, in the desert or on the plains

Wind mills are usually placed where wind conditions are ideal. Salt water, ice, sand storms, high humidity, and extreme temperature changes make the environment less than ideal for most electromechanical components. Thomson actuators and screw jacks are available with protection up to IP67 and are tough enough to do the job.



Why Choose Thomson?

Often the ideal design solution is not about finding the fastest, sturdiest, most accurate or even the least expensive option. Rather, the ideal solution is the optimal balance of performance, life and cost. Thomson is best positioned to help wind and solar power machine builders quickly configure the optimal mechanical motion solution for each application.

The largest linear actuator range in the market

In addition to our extensive application and engineering expertise, Thomson has the largest, unmatched range of electrical linear actuators, precision linear actuators and screw jacks in the market today. We provide positioning solutions for a vast array of unique applications for dynamic loads up to 11,240 lbf. Thomson understands the critical needs of the clean energy industry and works diligently to provide the most cost-effective solutions available. Our success is driven by:

- decades of application and engineering expertise
- robust and reliable products that withstand the harshest environments
- an extensive standard and modified product range
- custom designs for unique applications.

Rugged and reliable

Thomson products suitable for applications in the clean energy industry are rugged and reliable, withstand harsh environments and are protected to IP67.

Changing technologies

Manufacturers are taking a long, hard look at the way they use motion control systems in their equipment. Once dominated by pneumatic and hydraulic systems, machines are now more often designed to use electric linear actuators for the automation of many tasks. They are easier to control, integrate with control systems and are smaller, lighter and cleaner than hydraulic systems – all attributes that brighten a company's bottom line. Electric linear actuators or screw jacks eliminate:

- hydraulic pumps, valves and hoses
- cost and bulk associated with hydraulic systems
- environmentally hazardous oil and risk of leakage
- high energy consumption of hydraulic systems
- costly hydraulic reliability issues (contamination)
- cost and hassle associated with fluid maintenance.

At Thomson, Customization is Standard

Thomson is the industry leader in custom design. Our design flexibility and unique customization expertise give us an advantage to quickly provide customers a cost-effective design that meets their exact requirements.



Linear Actuators Overview

For 80 years, the dedicated engineers at Thomson have designed linear actuators to provide performance in some of the most demanding applications - vibration, shock, heat, cold, salt spray. Today Thomson has the largest unmatched range of standard and custom electrical linear actuators in the market.

Electrak 10

- Robust, strong and reliable
- Withstands very harsh environments
- Stainless steel extension tube
- Acme or ball screw models
- A variety of DC voltage models
- Clevis mounting



Electrak PPA

- Strong and versatile heavy duty actuator
- A variety of AC and DC voltage models
- High duty cycle
- Long stroke lengths
- Large range of options
- Trunnion mounting

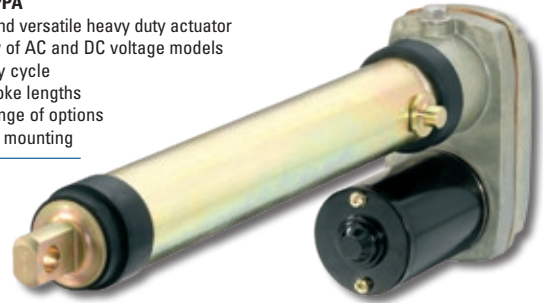

Electrak LA24

- Robust, strong and reliable
- Withstands very harsh environments
- Aluminium cover tube
- Acme or ball screw models
- A variety of AC voltage models
- Trunnion or clevis mounting



Electrak Pro

- The next generation in actuator design
- Designed for the harshest applications
- Electronic load monitoring (ELM)
- Small size with minimal retracted length
- Acme or ball screw models
- IP66 protection as standard
- Manual override as standard
- Wide range of options
- Clevis mounting

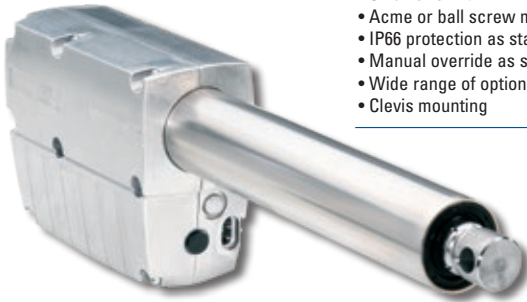

Supply voltages	12, 24, 36 VDC and 115, 230, 400 VAC
Speed range	0.004 - 2 inch/s (0.1 - 50 mm/s)
Dynamic load, maximum	2000 lbf. / 9000 N
Static load, maximum	3000 lbf. / 13500 N
Stroke length, maximum	36 inches (941 mm)
Protection degree, maximum	IP 67
Feedback options	potentiometer or encoder
Limit switch options	external or internal adjustable / internal programmable
Mounting options	clevis, tube mounting or trunnion
Controls	a large range of controls are available



Precision Linear Actuators Overview

Thomson Precision Linear Actuators are our top-of-the-line actuators. They are built to be strong, robust and reliable, yet very accurate and flexible. They are available in three different sizes, each with many different mechanical configurations, motor alternatives and mounting options. Thomson Precision Linear Actuators have the reliability, accuracy and functional flexibility to suit almost any application with guaranteed trouble-free operation in the toughest environments.

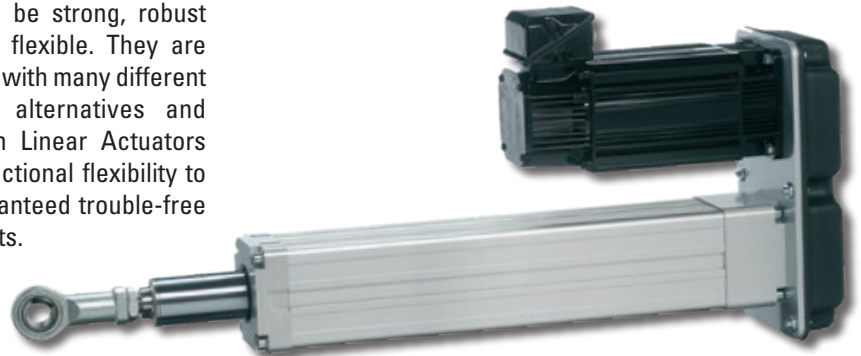

ECT-series

- Very robust, strong and reliable
- Withstands harsh environments
- Hard chromed extension tube
- High precision ball screw drive
- 100 % duty cycle
- 3 phase AC motor or AC-servo motor
- High repeatability



T-series

- Strong, compact and versatile
- Hard chromed extension tube
- High precision ball screw drive
- Three different sizes
- Large range of mounting options
- High speed, repeatability and long life
- Available with wash down protection

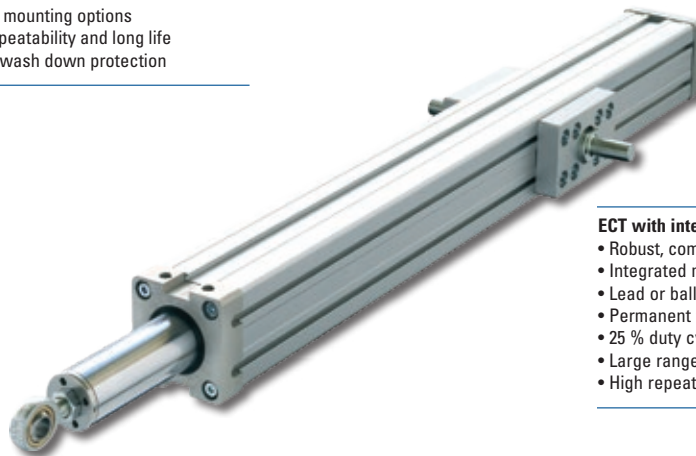

ECT with integrated DC motor

- Robust, compact and durable
- Integrated motor in the profile
- Lead or ball screw drive
- Permanent magnet DC motor
- 25 % duty cycle
- Large range of options
- High repeatability

Motor alternatives	24VDC, 400 VAC 3 phase and AC-servo as standard (others on request)
Speed range	0.04 - 118 inch/s (3000 mm/s)
Dynamic load, maximum	13400 lbf. / 60000 N
Static load, maximum	17900 lbf. / 60000 N
Stroke length, maximum	79 inches
Protection degree, maximum	IP65
Feedback options	encoder, resolver, smart feed back device (SFD)
Limit switch options	magnetic sensors
Mounting options	clevis, trunnion or mounting feet
Controls	various alternatives available (motor dependent)

Screw Jacks Overview

The Thomson screw jack product line provides reliability and versatility in a variety of applications. Technically mature, and with an easy-to-mount, rectangular housing, it can easily be extended to form wide-area jack systems with the help of its wide range of accessories.

Thomson screw jacks

- Models with moving or rotating screw available
- Models available that can provide thrust to operate large numbers of solar panels simultaneously
- Can easily be synchronized with other units to drive multiple rows of solar panels
- Very stiff system to provide highly accurate positioning
- Slow extension speeds - down to 0.0001 inch extension per each revolution input
- Very low maintenance
- Optional limit switches for end of stroke protection
- Variety of motor flange adapters to allow customer preferred motors
- Designed with high quality components and materials to be robust and offer long and trouble-free operation under the toughest conditions.



Supply voltages	motor and drive dependent
Dynamic load, maximum	11,240 lbf.
Limit switch options	external adjustable
Mounting options	clevis or trunnion
Controls	various alternatives available (motor dependent)

Contact us or any of our 2000+ global distribution partners by scanning the code below
or visiting www.thomsonlinear.com/contact



RegalRexnord™

www.regalrexnord.com

www.thomsonlinear.com

Clean_Energy_Applications_CPEN-0010-01 | 20260329KB | MCB-12423-TL-EN-US 03/26
Specifications are subject to change without notice. It is the responsibility of the product user to determine
the suitability of this product for a specific application. All trademarks property of their respective owners.
©2026 Thomson Industries, Inc. | 2400 Curtiss Street, Downers Grove, IL 60515 USA

THOMSON®